



Midea

AG AIRCON

Midea Aircon Catalogue



6 YEARS COMPRESSOR WARRANTY
*Applicable for residential aircon only
First 2 Years
General On Site Warranty
Peace of Mind

XTREME
SaveE

4
INVERTER
QUATTRO





CARVED FROM 50 YEARS OF EXPERIENCE

make yourself at home

Midea, established in 1968 is a public company listed and since July 2016 a Fortune 500 company offering one of the most comprehensive ranges in the home appliances industry. Midea specializes in air treatment (residential and commercial solutions), refrigeration, laundry, cooking appliances, small kitchen appliances, water appliances, floor care and lighting.

more than
\$36 Bn
of revenue in

serve
customers in
200+
countries

32
global
production
facilities

136,800
employees
worldwide

Global Fortune
500
company



Stay cool, save more



Smart Save Mode 

Save your money as well as the worries on energy consumption with Midea's SmartSavE mode. Simply power on your Midea air conditioner and select the mode for a full night's energy-efficient comfort. With the ultra-low energy needed, now you can enjoy a restful sleep.

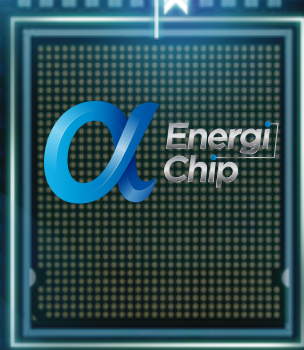

Precise-Control Algorithm

Midea's Innovative SmartSavE mode uses the Alpha Energy Chip's 4th SmartSavE Precise-control Inverter Deduction Algorithm, which enables the chip to do more precise signal receiving, accurate data processing, anticipating and prompt instructions sending to the compressor.

This helps the inverter compressor to work more efficiently to save energy while ensuring you're comfortable and cool.

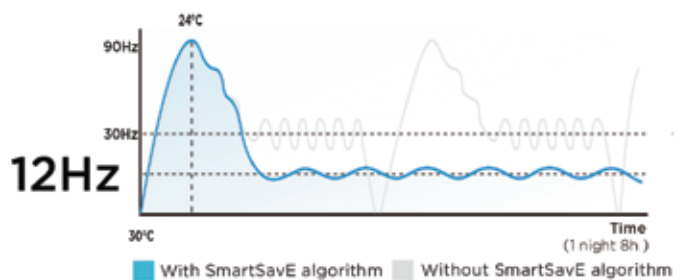
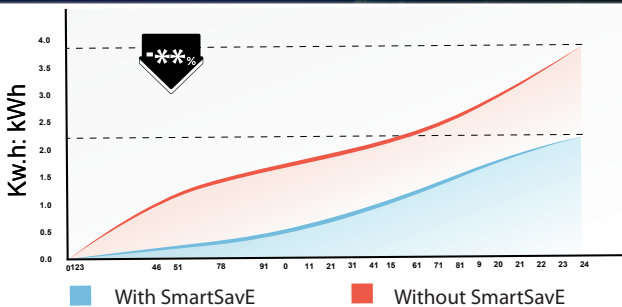
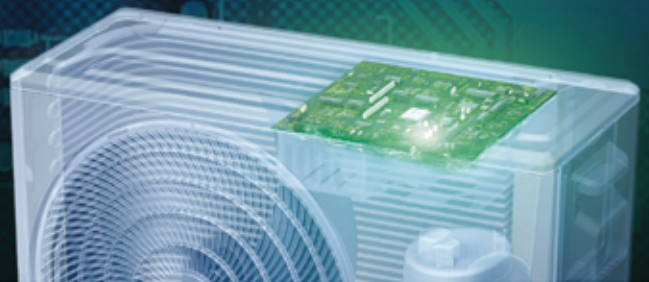

Just click the SmartSavE button to activate the mode: your AC can keep you cool over an **8-hour** night period.

The Inverter Quattro™ supports continuous compressor operation at ultra-low speed of **12Hz**. Thanks to the SmartSavE precise-control algorithm, ultra-stable frequency is achieved with minor vibration which decreased by up to **16 times**.



Energy Saving

High-efficiency Fan Blade and Ducts



Ordinary fan blade design



Midea high static pressure fan blade design

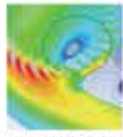

Standard air duct damper

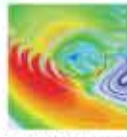

High-efficiency air duct damper

The optimized air fan and ducts deliver the same airflow in with 30 percent less power thanks to the advanced designs. It makes Midea's air conditioner an unbeatable choice for energy saving.

↓30%

Power Required for Same Air-volume



Midea inverter air conditioners offer three operating power options: 50%, 75%, and 100%. You can choose a lower power level with the Gear button on the remote controller to conserve energy when you feel the cool is enough.

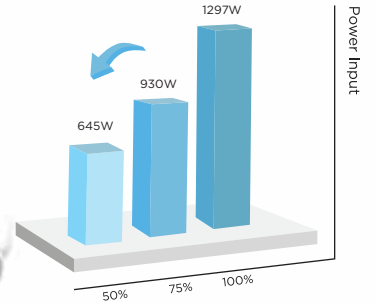

Powerful Cooling



Flash Cooling

Thanks to the Inverter Quattro™'s High Frequency Racer Tech, Midea air conditioner is able to lower the room temperatures by 23°C within 40 seconds.



Comfort

ThermoStatic Technology

Keeping you steadily cool within $\pm 0.5\text{ }^{\circ}\text{C}$

Thanks to the precise control of the Inverter Quattro™'s micro-chip, Midea's air conditioner can easily maintain the desired temperature by varying the compressor speed without repeatedly turning on and off, keeping you feel comfortable with steady temperature within $\pm 0.5\text{ }^{\circ}\text{C}$.



Healthy

Dual Filtration

The Dual Filtration system thoroughly eliminates harmful substances through the 2 steps, providing fresh and clean air to you.

STEP1: High Density Pre Filter

Dust



Dog hair



Dead mite feces



Fung

STEP2: Micro Protection Filter

Pollen (Allergen), smoke, micro dust (under $0.3\mu\text{m}$)



Flower pollen



Bacteria



Car exhaust fumes



Smoke

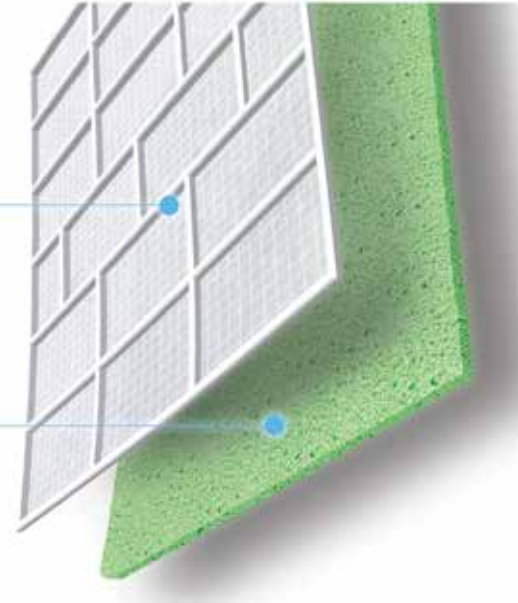

Features



Gear Shift



Flash Cooling



High Density Filter



iECO Mode



Low Noise



Full DC Inverter



Fire Proof Electric Box







Diamond Cabinet



Follow Me



Specifications

| | | Model | | | | |
|--------------------------------|-----------------------|---|---|---|---|------------------|
| Indoor | | MPAG-09C | MPAG-12D | MPAG-18B | MPAG-24B | |
| Outdoor | | MPAG-1S09C | MPAG-1S12D | MPAG-1S18B | MPAG-1S24B | |
| Power Supply | V-Ph-Hz | 220-240V / 1Ph / 50Hz | | | | |
| Capacity | Btu/h | 8871 (4305-10986) | 11942 (5600-13000) | 18000 (8380-21200) | 24000 (9553-26272) | |
| Input | W | 720 | 790 | 1550 | 1930 | |
| EER | W/W | 3.60 | 4.43 | 3.40 | 3.64 | |
| COP (Full / Weighted) | | (3.88 / 4.51) | (4.55 / 5.34) | (3.63 / 4.24) | (3.64 / 4.43) | |
| Rated Current | A | 3.16 | 3.50 | 6.70 | 8.62 | |
| Max. Input Consumption | W | 2150 | 2300 | 2500 | 4050 | |
| Max. Current | A | 10.0 | 10.5 | 13.0 | 17.5 | |
| Indoor Air Flow (H / M / L) | m3/h | 460 / 330 / 260 | 530 / 380 / 310 | 800 / 600 / 500 | 1090 / 900 / 825 | |
| Indoor Sound Level (H / M / L) | dB(A) | 37.0 / 32.0 / 22.0 | 39.0 / 32.5 / 30.0 | 41.0 / 37.0 / 31.0 | 45.0 / 39.0 / 33.5 | |
| Indoor Unit | Dimension (W x D x H) | mm | 726 x 210 x 291 | 802 x 200 x 295 | 969 x 241 x 320 | 1082 x 234 x 337 |
| | Packing (W x D x H) | mm | 790 x 270 x 375 | 875 x 285 x 380 | 1045 x 315 x 405 | 1155 x 415 x 315 |
| | Net / Gross Weight | Kg | 8.0 / 10.5 | 8.5 / 11.1 | 11.2 / 14.6 | 13.3 / 17.0 |
| Outdoor Sound Level | dB(A) | 55.5 | 55.5 | 57.0 | 61.0 | |
| Outdoor Unit | Dimension (W x D x H) | mm | 720 x 270 x 495 | 805 x 330 x 554 | 805 x 330 x 554 | 890 x 342 x 673 |
| | Packing (W x D x H) | mm | 835 x 300 x 540 | 915 x 370 x 615 | 915 x 370 x 615 | 995 x 398 x 740 |
| | Net / Gross Weight | Kg | 23.5 / 25.4 | 32.2 / 34.9 | 33.5 / 36.1 | 43.3 / 46.4 |
| Refrigerant Type | Kg | R32 / 0.6 | R32 / 0.9 | R32 / 1.1 | R32 / 1.4 | |
| Piping | Liquid / Gas | mm | 6.35 / 9.52 | 6.35 / 9.52 | 6.35 / 12.70 | 9.52 / 15.88 |
| | | inch | 1/4" / 3/8" | 1/4" / 3/8" | 1/4" / 1/2" | 3/8" / 5/8" |
| | Max. Length | m | 25 | 25 | 30 | 50 |
| | Max. Height | m | 10 | 10 | 20 | 25 |
| Drain | mm | 19 | 19 | 19 | 19 | |
| Operation temperature | °C | 17~30 | | | | |
| Energy Labelling Scheme | |  |  |  |  | |

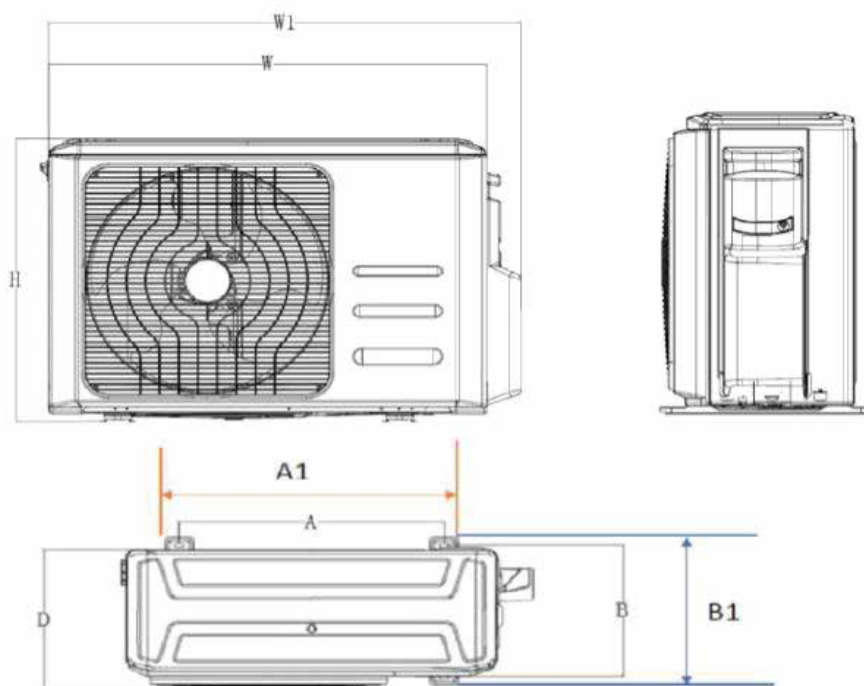

| Model | Ticks | W | H | D | W1 | A | A1 | B | B1 | Net W (Kg) |
|---------------------|-------|-----|-----|-----|-----|-----|-----|-----|-----|------------|
| Single Split | | | | | | | | | | |
| MPAG-1S09C | 3 | 720 | 495 | 270 | 790 | 452 | 501 | 269 | 298 | 23.5 |
| MPAG-1S12D | 4 | 805 | 554 | 330 | 874 | 511 | 569 | 317 | 346 | 32.2 |
| MPAG-1S18B | 2 | 805 | 554 | 330 | 874 | 511 | 569 | 317 | 346 | 33.5 |
| MPAG-1S24B | 2 | 890 | 673 | 342 | 955 | 663 | 737 | 354 | 394 | 43.3 |



MD (SINGAPORE) Consumer Product Co. Pte Ltd

151 Lor Chuan, #04-05 (Lobby E), New Tech Park, Singapore 556741

Website: www.midea.com.sg

Customer Service Hotline: +65 6655 7666