

Designed to be installed on the ceiling with separate reservoir and self priming

- Designed to install with wall mounting type air conditioners.
- Ultra Quiet pump with strong performance.

Special features

- 1 Designed for installing on the ceiling or near wall mounting type air conditioners
- 2 Pump body and reservoir are separated
- 3 3m suction head
- 4 Ultra Quiet pump with strong performance
- 5 Low power consumption
- 6 Mesh filter inside of reservoir
- 7 Built-in safety switch

Technical specifications

- Power Supply : 110V~120V 60Hz or 220V~240V 50/60Hz
- Water Flow rate : Max 29l/hr at 0 meter
- Discharge head : Max 8M
- Suction head : 3m
- Ambient temperature : 0°C ~ 50°C

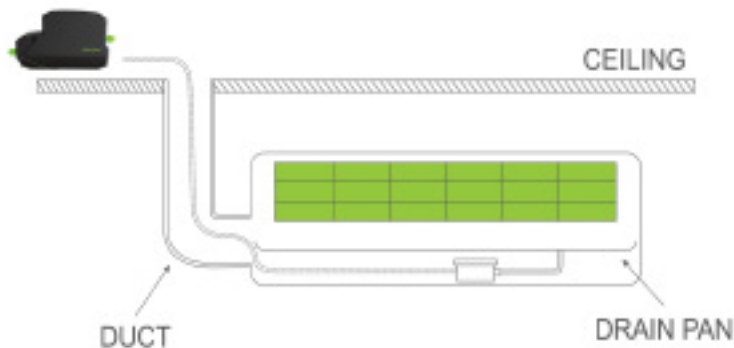

Performance

Model	Power Supply	Performance(l/hr@Height in Meter)				Max. Lift		Amps	Watts
		0m	4m	6m	8m	Meter	Ft		
MD800CD	120V, 220~240V 50~60Hz	29	19	15	12	8m	26ft	0.024A	2.5

Dimensions

Weight	Tank Capacity	O.D of Outlet
160g	35ml	8mm

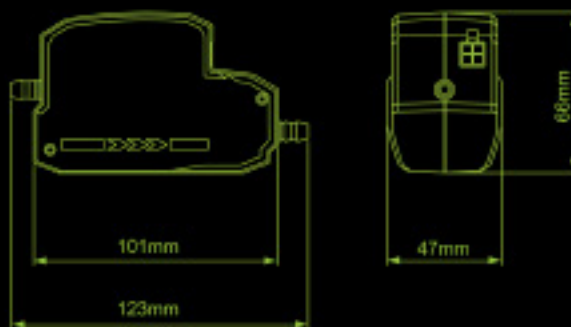

Ultra Quiet

SUNGSHIN Hasco | Never-Ending Innovation Its Goal is the Customer Satisfaction | 010

Distributed By:



12 Kallang Way North East Building
Singapore 349216
sales@northeast.com.sg
Tel: 67492832